

PRODUCT DESCRIPTION OF HAMMER

HAMMER FRAME



Hammer Plast uses the highest quality materials, technologies and tools that contribute to the high quality profiles production. Hammer Plast profiles are among the first ecological profiles, made in Europe with a calcium-zinc stabilizer. According to the European standards, our company uses up to 32-mm glass for high quality noise and heat insulation. Number of cameras - 6 and overall width of profile - 72mm. The production cycle is facilitated by the use of reinforcement metal profile. The profiles production takes place in a modern base, located in 13,000 square metres area. The company aims to implement the idea of a new technology, launching a new type of production, unlike the previous, but also related to it. This idea is backed by solid experience of the firm and serious researches of the domestic and international markets.

In the early 2008th the idea has become a reality. The purchased production line of PVC profiles for windows and doors, carrying their own brand HAMMER Plast, is already operating successfully. System profile is developed with specialists from the German and Austrian companies, which are world leaders in this field. It's done with the participation of international specialists also, who have successfully completed training in the School of Greiner Extrusionstechnik.

The fully automated production process and permanent control, exercised over raw materials, processing and final products, guarantees the quality of the profiles. Impact on the quality has the experience of the staff, which is trained and worked more than a decade, using extruders and newest trend in the profile production, which is the use of environmentally friendly profile with calcium - zinc stabilizer. The company is certified according to the international standard EN ISO 9001:2000.



KOZIJNPRO® Kozijnen en Deuren

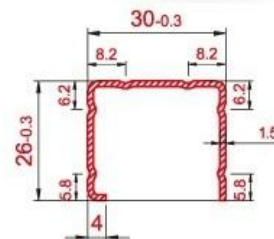
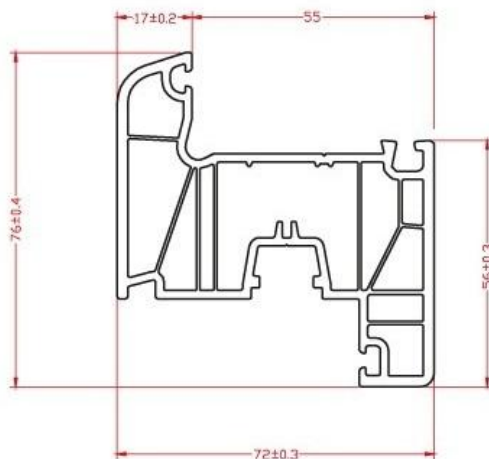
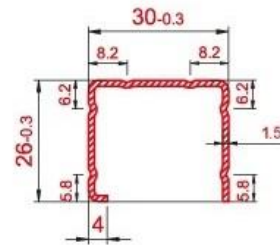
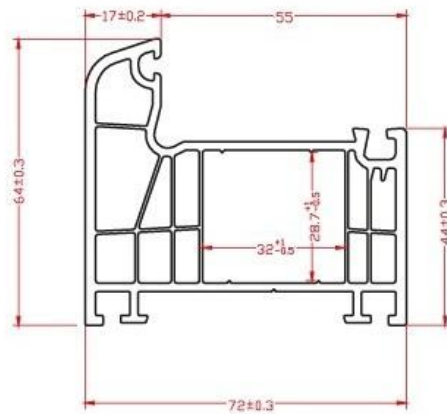



KOZIJNPRO® Kozijnen en Deuren

